

ER45e

Quick Reference Guide

E-Series Ethernet Radios



1.0 Introduction

Welcome to the Quick Start Guide for the ER45e Ethernet Radio. This guide provides step-by-step instructions, with simple explanations to get you up-and-running. For further information, please refer to the Ex45e User Manual.

Typical Radio Setup

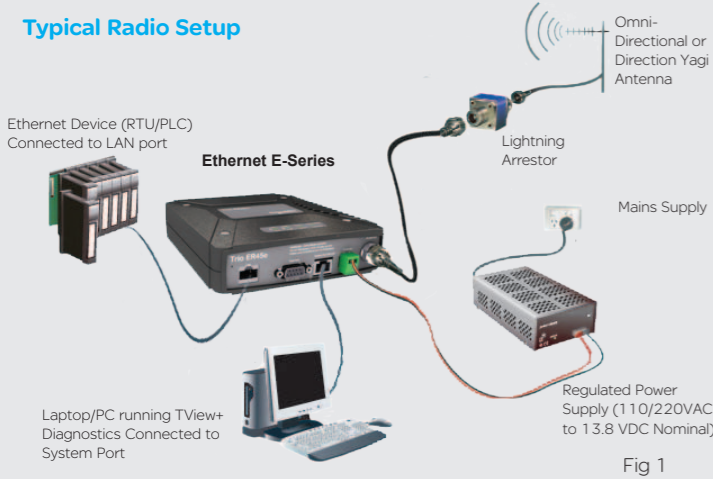

Fig 1

2.0 Mounting and Installation Instructions

The radio should be mounted in a clean and dry location, protected from water, excessive dust, corrosive fumes, extremes of temperature and direct sunlight. In high power or high temperature applications, please allow sufficient passive or active ventilation. To avoid moisture ingress, mount the radio with the connectors facing downwards.

5.3 System Port - RJ45:

The system Port is a multi-function interface used for: Programming/ configuration of the Radio Remote diagnostics connections To access these functions use the standard ER45e System Cable assembly (RJ45 Cable and RJ45 to DB9 Adaptor).

Special user pinouts:

- Shutdown (Pin 4) - Active low for power safe function
- External PTT (Pin 8) - Provides a manual PTT override facility for enabling the transmitter.

Note: For testing this can be activated by

Connecting PTT (Pin 8) to GND (Pin 7).

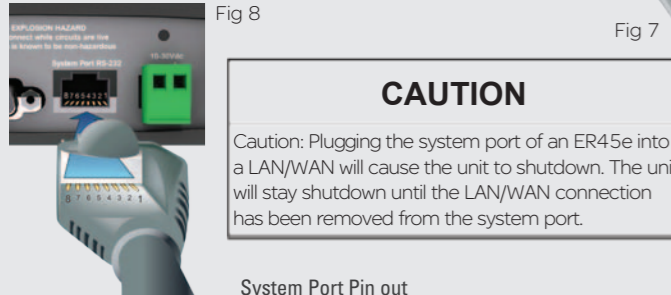

System Port	Description	DB9 Female
Pin 1	System port data out (RS232)	Pin 2
Pin 2	System port data in (RS232)	Pin 3
Pin 3	Factory Use Only - Do not connect	No Connection
Pin 4	Shutdown	No Connection
Pin 5	Programming Use Only (Grounded)	Pin 5
Pin 6	Factory Use Only - Do not connect	No Connection
Pin 7	Ground	Pin 5
Pin 8	External PTT	No Connection

Fig 9

Please choose an enclosure that is suitable for the size of the radio. Dimensions are available in the Ex45e User Manual. The radio is rated for use in ambient (operating) environments from -30°C to +60°C.

3.0 Connecting Antennas and RF Feeders

The RF antenna system should be installed in accordance with the manufacturers notes. Antenna gain must be considered when setting Transmit Power.

The RF connector on this product is an N Type female connector. Always use good quality low loss feeder cable, selected according to the length of the cable run. Ensure all external connections are waterproofed.

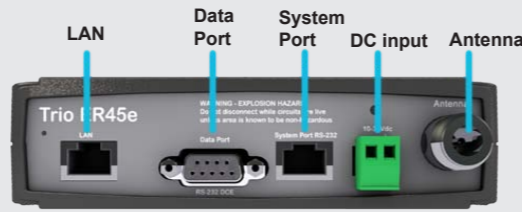

Fig 2

4.0 Power Supply Requirements

Nominal Operating voltage: 13.8V DC (Filtered)
 Transmit Current: 750mA nom @ 1W, 1700mA nom. @ 5W
 Receive Current: 150mA nom
 Rated Operating Voltage 10 - 30 Volts DC (filtered)

The ER45e Radio is supplied with the a mating DC power connector: Phoenix Contact Part Number 1744099. The DC power connector should be secured with the supplied Power lead retainer. Cable must be #22 AWG or larger, 70°C min. temperature rating. CSA maximum current rating: 2.5A. Connections to the power terminal and DB9 port connector must utilize mating plugs that are secured in place by integral screws.

The radio is designed to self protect from permanent damage if the voltage exceeds 30V DC. The replaceable internal fuse has a 5 Amp rating. (Fuse -Trio Part No. SM%FUSSQ5A) 5A Fast Acting. These fuses can be obtained from the following suppliers: Farnell P/N: 9922199RL, Digkey P/N: F2587CT-ND, Mouser P/N: 576-0451005.MRL

6.0 Activating the Transmitter

In most systems, the transmitter by default is controlled automatically by the radio when it has data to transmit. In some systems, such as full duplex point-to-point or full duplex point-to-multipoint base stations, it is desirable to run the transmitter all the time (hot keyed). you can 'hot-key' a radio by tying pins 7 & 8 together on the radio's system port.

CAUTION

Caution: When the radio is configured to transmit continuously, ensure an RF load is present BEFORE applying power to the unit.

7.0 Optimising The antenna for RX Signal

Once the unit is operational, it is important to optimise the antenna tuning.

in the case of a directional antenna, it will be necessary to align the antenna for the best received signal.

This can be done by using the (0 - 5Vdc) output Pin 9 (See Fig 10) of the Data Port to indicate signal strength (RSSI). This voltage can be converted to dBm using the chart below (Fig 9).

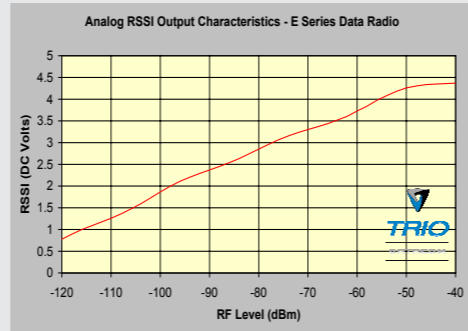

Fig 9 Chart is approximate only.



Fig 10 Data Port, Pin 5, Signal Ground

The current requirement is typically 150mA @ 13.8 V DC in receive mode, and will vary in transmit mode according to RF output power level & duty cycle.

CAUTION

The radio modem can be damaged if there is any potential difference between the chassis-ground, RS232 signal ground, power (-) input, or antenna coaxial shield.

Before connecting any wiring, ensure all components are earthed to a common ground point.

Connect the antenna, ethernet and RS 232 plugs BEFORE applying power to the unit. Lastly, before inserting the power plug, please re-check that the polarity and voltage on the DC power plug is correct using a multimeter.

5.0 Communication Ports

5.1 LAN Ethernet Port

The LAN port is a 10/100 Base-T compliant port using an RJ-45 connector. These ports support both TIA/EIA-568-A & B wiring as they have Auto MDI/MDIX Auto Sensing. This means you can use both straight-through and cross-over type CAT-5 or better patch cables. All RJ45 connectors must utilize mating plugs that include an integral locking tab.

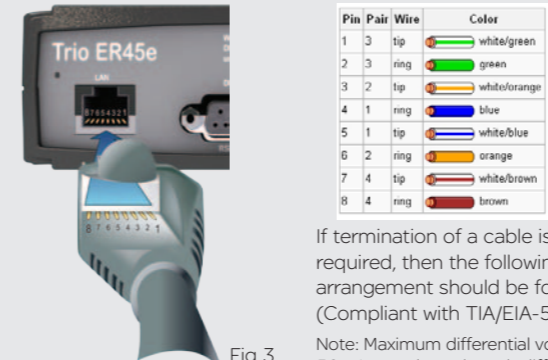

Fig 4

If termination of a cable is required, then the following wiring arrangement should be followed (Compliant with TIA/EIA-568-A).

Note: Maximum differential voltage : 5v, 50mA max through each differential pair.

Note: If 100-BaseT connection speed is required, CAT-6 Shielded cable should be used for installation to comply with ETSI EMC directives.

5.2 Data Port

The ER45e Radio features a 9 pin miniature D-Shell (DE-9) Female connector that supports one individual serial port connection. The serial port is wired as an RS232 DCE, configurable for no handshaking (3-wire) interface, or for hardware or software (X-on/X-off) flow control. In most systems flow control is not required, in which case only 3 wires need to be connected between the radio and the application device.

Typical Pins used:

- Pin 2 (Rx/D) - Data Output from the Radio Modem.
- Pin 3 (Tx/D) - Data input to the Radio Modem.
- Pin 5 (SG) - Signal Ground.

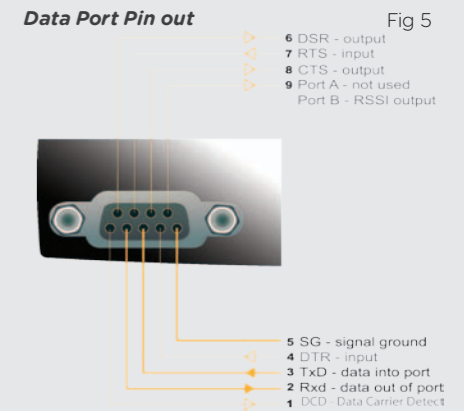

Fig 5

Note: Please refer to the Ex 45e User manual for further details of other cable configurations.

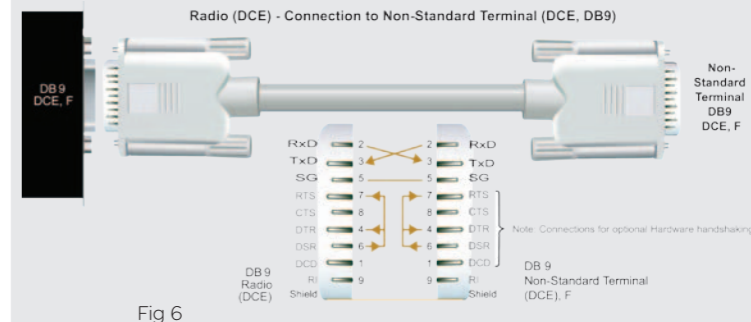

Fig 6

8.0 ER45e Factory Default

8.1 Introduction:

Please read the following notes carefully. Configuration errors with Ethernet connections can be difficult to find and resolve. It is strongly recommended that you follow these guidelines.

8.2 IP Address and Factory Default Reset

The factory default IP address of the ER45e is 192.168.2.15. If you do not know the IP address of the ER45e you can either read the unit using the TVIEW programmer or perform a factory default.

A factory reset will cause all previous configuration settings to be erased and returned to the factory default values. A factory default can be initiated by applying DC power to the radio (wait 45 seconds), depress the factory default switch using a paper clip or similar object and keep the switch depressed for 5 seconds until all five LEDs illuminate solid GREEN indicating the radio will return to the factory default settings. Please wait 45 seconds for the factory default reset process to complete.

Factory Default Button



Fig 11

9.0 Resolving Ethernet Configuration Problems

Here are some basic tips to help you along the way with Ethernet configuration problems. The Windows operating system (and others) comes complete with many useful tools. First, you need to open a command window. This can be done by clicking on "Start" then "Run" and entering "CMD" and clicking OK.

9.1 Obtaining IP information about your PC

If you need to find out more information about your computers Ethernet IP configuration, network gateways and DNS servers, you can use a tool called "IPConfig". Simply type "IPconfig /all" into your command window.

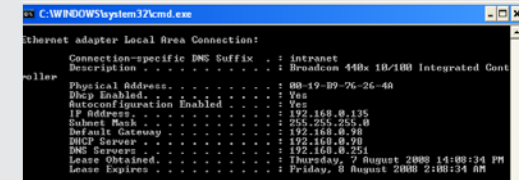

9.2 Checking IP connectivity

The most reliable way to check IP connectivity to a device is using the "Ping" utility. Type "ping xxx" where xxx is the complete IP address of the destination device you want to check. Ping will either respond with latency results (as shown) or say "timed out" if no connection was possible.

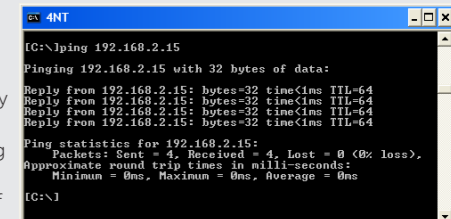

9.3 Repeated connections to multiple devices with same IP address

A common problem experienced when attempting to configure multiple radios with the same IP address (such as factory default radios). The problem is due to invalid MAC table entries. If you change your ethernet connection between two devices with the same IP address quickly, you may need to reset the MAC look up table in your PC. You can do this by typing "arp -d *" in the command window.

ER45e Quick Start Guide

E-Series Ethernet Radios Step-by-Step Point to Point Setup

Introduction

This document describes the 5 key steps required for configuring the radio and demonstrating Modem operation and communication over-the-air on a pair of factory default, ER45e half duplex radios operating in Point to Point (PTP) mode. After successful testing is achieved, subsequent testing can then be done on user equipment such as RTUs or PLCs.

For more information consult the following documents:

- ER45e E-Series Ethernet User Manual
- TVIEW+ Diagnostics User Manual

Typical Radio Setup



Fig 12

9

4) Ensure your PC LAN port is configured for a suitable IP address. You can do this by configuring the LAN settings via the control panel. Navigate to your windows "Start" button and open Control panel -> Network Connections -> Local Area Connection -> Properties. Scroll down and select "Internet Protocol (TCP/IP) Properties" then click on Properties. You should now see a window shown in Fig 16. Ensure "Obtain IP Address Automatically" is NOT selected. It is recommended that you manually specify a compatible IP address. In this example, we are performing a ping test on a factory default radio. The IP address of the radio is 192.168.2.15 and a compatible IP address for the PC would be 192.168.2.1. Click OK to accept the changes.



Fig 16

Note: Check with your system administrator before allocating IP addresses as each LAN/WAN network is different.

5) Open up a command window on your PC by going to the "Start" -> Run and typing "CMD" then OK. Then type "ping 192.168.2.15" (Example: this is the default address of the radio). If both the radio and PC have their LAN port connection and configuration correct, the radio will respond to the ping as shown in Fig 17. If this is not the case, check you network settings as described in the previous step.

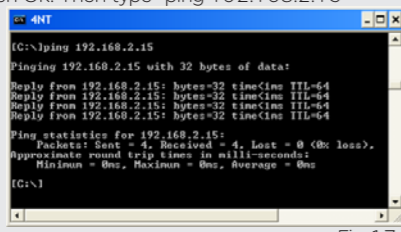

Fig 17

6) Once successfully completing the ping test with your locally connected radio, stay locally connected to the same radio, but now ping the IP address of the remotely connected radio. If all connections and configurations are correct, the remote radio will respond in the same way.

13

Step 1 - RF and DC power connection

RF Connection

To simulate a long distance RF link on your test bench, the recommended method is to use RF attenuators. RF attenuators are far superior to antennas for short-distance bench testing as the attenuation of the RF signals between both radios is consistent and is not subject to external interference. Alternatively 90dB of separation can be achieved with 50 ohm dummy loads or small whip antennas (minimum separation 1m (or 3ft).

(1) If the TX power of each radio is set to 20dBm (100mW) low power, low cost attenuators can be used.

(2) Ensure the signal into the receiving radio is no greater than -30dBm (set Tx power on all radios to 20dBm).

DC Power Connection

Ensure each radio is wired using the correct polarity and that power supply is regulated and has adequate current delivering capacity.

Step 2 - Power Up Radios

Nominal Operating voltage: 13.8V DC (Filtered)
Transmit Current: 750mA nom @ 1W, 1700mA nom. @ 5W
Receive Current: 150mA nom
Rated Operating Voltage 10 - 30 Volts DC

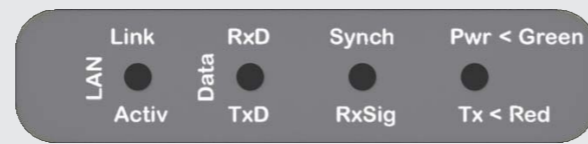

Apply DC power to the radios. The "Pwr" LED should now be solid GREEN. Wait for 30 secs before attempting to read the unit with the programmer (During boot, other LEDs may flash). If there is no LED indication, the internal fuse may have opened. Re-check the DC polarity and ensure the DC voltage is between 10V and 30V. Also check that you have NOT plugged your units system port into your LAN/WAN, as this will also cause all LED indicators to turn off.

10

Step 3 - TVIEW+ Management Suite

TVIEW+ Management Suite allows a number of features including: Configuration (Local - Serial, or over-the-air) and Remote Diagnostic Facilities.

The configuration wizard can be used to provide Quick Start generic templates for the types of system architecture you wish to employ.

Example: Local configuration session -

- 1) Launch TVIEW & Select "Programmer"
- 2) Ensure radio is powered up and ready as described in Step 2.
- 3) Attach the programming cable from the PC to the system port of a radio. Ensure you DO NOT connect the programming cable into the LAN port.
- 4) Select "Read" to read the Local Radio
- 5) Select "Wiazrd"
- 6) Select "PTP Half Duplex Link"
- 7) Adjust Tx Power to 20dBm
- 8) Configure and save IP Parameters and frequencies
- 9) Select "Write"



Fig 13

11

Step 4 - Checking RF Link

The RF link can be checked by energising the transmitter of your master radio. To energise the transmitter review the instructions in Section 6.

Now that the transmitter has been energised on your master radio take a look at the LED indicators on the MASTER unit. They should look like Fig 14:



Fig 14

The SOLID RED LED indicates that the units transmitter is energised. as for the REMOTE unit, the LED indicators should look like Fig 15:



Fig 15

The SOLID GREEN synch LED indicates the the receiver is synchronised. Once completed, turn off the Transmitter on the MASTER and energise the Transmitter on the REMOTE unit, verify correct LED operation.

Step 5 - Verify Modem Operation

Now that you have verified an RF link you should verify you can communicate between each ER45e. To do so you should perform a 'Ping Test'.

- 1) Ensure the ER45e is powered and has fully booted. This is indicated by a solid green power LED. It takes about 45 seconds for the radio to fully power up.
- 2) Disconnect your PC from any other internet/LAN networks. Failure to do so may cause a conflict in IP addresses or the ER45e might not meet the subnet mask specified by your network.
- 3) Connect your PC Ethernet port to the units LAN port using an RJ-45 Patch cable. Cross over cables will also work. Successful cable connection is indicated by a solid Green "Link" LED on the LAN port.

Note: The LAN port will also flash amber when data is being transferred.

12

4) Ensure your PC LAN port is configured for a suitable IP address. You can do this by configuring the LAN settings via the control panel. Navigate to your windows "Start" button and open Control panel -> Network Connections -> Local Area Connection -> Properties. Scroll down and select "Internet Protocol (TCP/IP) Properties" then click on Properties. You should now see a window shown in Fig 16. Ensure "Obtain IP Address Automatically" is NOT selected. It is recommended that you manually specify a compatible IP address. In this example, we are performing a ping test on a factory default radio. The IP address of the radio is 192.168.2.15 and a compatible IP address for the PC would be 192.168.2.1. Click OK to accept the changes.



Fig 16

Note: Check with your system administrator before allocating IP addresses as each LAN/WAN network is different.

5) Open up a command window on your PC by going to the "Start" -> Run and typing "CMD" then OK. Then type "ping 192.168.2.15" (Example: this is the default address of the radio). If both the radio and PC have their LAN port connection and configuration correct, the radio will respond to the ping as shown in Fig 17. If this is not the case, check you network settings as described in the previous step.

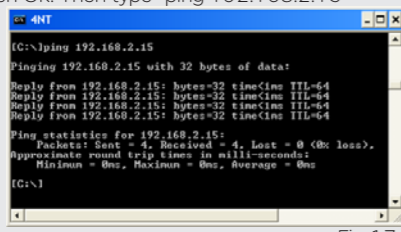

Fig 17

6) Once successfully completing the ping test with your locally connected radio, stay locally connected to the same radio, but now ping the IP address of the remotely connected radio. If all connections and configurations are correct, the remote radio will respond in the same way.

LED Indicators

DC Power :

If all the LEDs are off, no DC power is reaching the radio modem or the internal fuse is open. Successful power-up is indicated by the Pwr/Tx LED showing a continuous GREEN state.

Note: The ER45e radio will take approximately 45 seconds to boot up - during this time, other LEDs may flash. After the unit has fully booted, the DC power LED will remain solid green. (See Fig 18)

(ER45e Powered up)



Fig 18

Received Signal Indicator :

The "Rx/Synch" LED is used to indicate the state of the receiver. If the LED is OFF, no signal is being received. A RED indication shows that an RF carrier is being received but no data can be decoded. this may indicate the presence of interference, another user on the channel or an illegal user. (See Fig 19)

(Receiving un-decodable data)



Fig 19

A continuous GREEN indication shows that the modem is locked and synchronised to the incoming signal (See Fig 20). Any loss of synchronisation (BER Errors) is indicated as a visible RED flicker of the LED. (See Fig 19)

(Receiving decodable data)



Fig 20

LAN PORT:

The "Active/Link" LED is used to indicate the state of the LAN port. If the LED is OFF, there is no activity at all on the LAN port. A GREEN indication shows an established Ethernet link (See Fig 21). The LED will flash AMBER to indicate Ethernet data transmission is occurring (See Fig 22).

(Established Ethernet Link)



Fig 21

(Ethernet transmission occurring)



Fig 22

Data Port:

The RxD/TxD LED indicates data flow in/out of the data port. Data being sent to the port for transmission is indicated by a RED flash, and data being received over the air and then sent from the port is shown as a GREEN flash (See Fig 23).

(Serial Data sent out of the Data Port)



Fig 23

Error LED Indications:

In some circumstances the radio will indicate an error state. This is shown as all LEDs flashing RED for 1 sec and then a pattern of green or amber LEDs for 1 sec. The pattern of green or amber LEDs indicate the type of error. Please consult the user manual for further information.

Support Options - E-mail Technical Support

When e-mailing questions to our support staff, make sure you tell us the exact model number (and serial number if possible) of the TRIO Datacom equipment you are working with. Include as much detail as possible about the situation, and any tests that you have done which may help us to better understand the issue. If possible, please include your telephone contact information should we wish to further clarify any issues.

15

Important Notices for Class 1, Division 2 Groups A, B, C & D Hazardous Locations

Applies to models ER45e-xxxx-xHx(CSA Marked)

This product is available for use in Class I, Division 2, Groups A, B, C & D Hazardous Locations.

CSA certification is in accordance with CSA Standard C22.2 No. 213-M1987 and UL Standard 1604 subject to the following conditions of approval:

1. The radio modem must be mounted in a suitable enclosure so that a tool is required to gain access for disconnection of antenna, power and communication cables.
2. The antenna, DC power and interface cables must be routed through conduit in accordance with the National Electrical Codes.
3. Installation, operation and maintenance of the radio modem should be in accordance with the radio modem's user manual and the National Electrical Codes.
4. Tampering or replacement with non-factory components may adversely affect the safe use of the radio modem in hazardous locations and may void the approval.
5. A power connector with locking screws as supplied by Trio Datacom MUST be used.

WARNING EXPLOSION HAZARD

Do not disconnect equipment unless power has been switched off or the area is known to be non-hazardous. Substitution of components may impair suitability for Class I, Division 2. Refer to Articles 500 through 502 of the National Electrical Code (NFPA 70) and Section 18 of CSA C22.1 for further information on hazardous locations and approved Division 2 wiring methods.

Contact Details

Technical Support: The Americas

Available: Monday to Friday 8:00am - 6:30pm Eastern Standard Time
Toll free within North America: 1-888-226-6876
Direct Worldwide: +1 (613) 591-1943
Email: technicalsupport@controlmicrosystems.com

Technical Support: Asia Pacific

Available: Monday to Friday 8:30am - 5:30pm Australian Eastern Standard Time
Direct Worldwide: +61 3 8773 0100
Email: support@triodatacom.com

Technical Support: Europe, Africa, Middle East

Available: Monday to Friday 8:30am - 5:30pm Central Europe Standard Time
Direct Worldwide: +31 (71) 579 1650
Email: euro-support@controlmicrosystems.com